

CAD FILE:

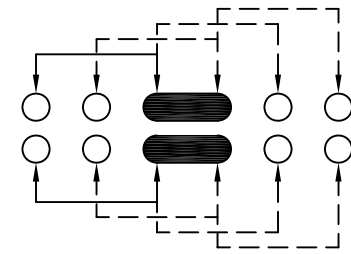

SCHEMATIC (SHORTING)

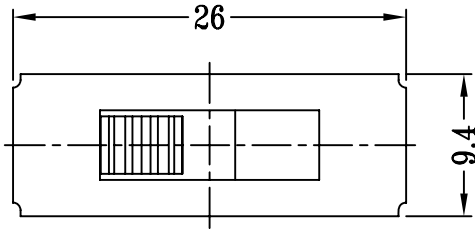
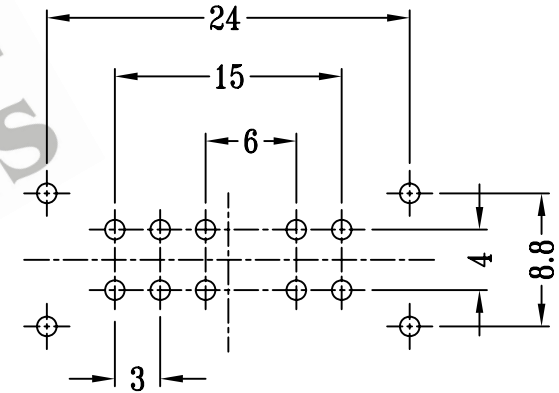
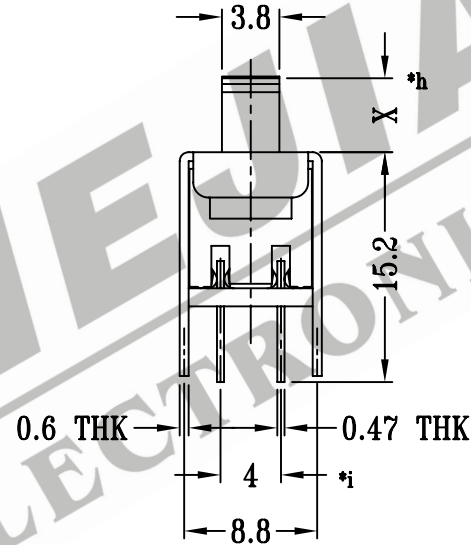
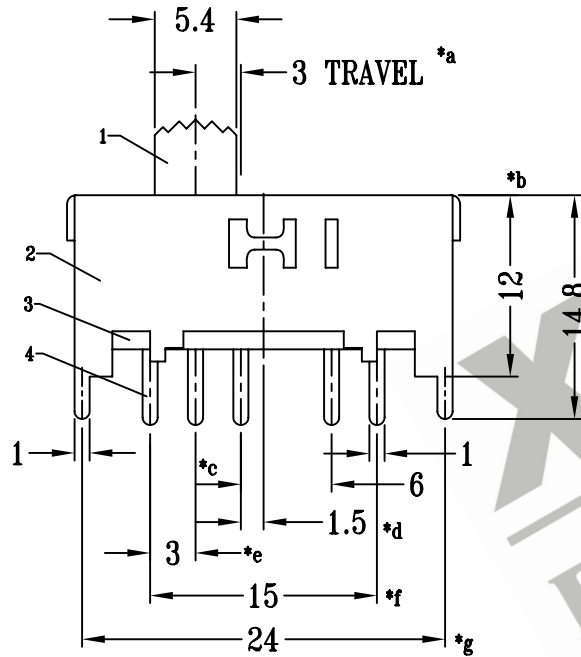

P.C.B LAYOUT

注:带*表示关键尺寸(9个)

NO.	PARTS	MATERIALS	Q'TY	FINISH	TOLERANCE UNLESS SPECIFIED	SHENZHEN XIEJIA ELECTRONICS CO.,LTD.						
8						ISSUE		DATE		DESCRIPTIONS OF REVISION		APPD.
7	STEEL BALL	STEEL	2	NATURAL	WITHIN: 1.5±0.1mm OVER: 1.5±0.2mm	TITLE: VERTICAL SLIDE SWITCH		UNIT: mm	DRWG NO.: XJ-DR-SS24F01-00			
6	SPRING	STEEL WIRE	1	TEMPER		MODEL: SS-24F01		SCALE: 2:1	DWN.	ZHOUYU	2003-4-17	
5	CONTACT (CLIP)	PBS STRIP	2	Ag PLATED		ALL MATERIALS MUST BE COMPLIANT TO ROHS			CHK'D	FANGYING	2003-4-17	
4	TERMINAL	BRASS STRIP	10	Ag PLATED OVER Ni PLATED					APPD.	KANGXINAN	2003-4-17	
3	TERMINAL BASE	PHENOLIC RESIN	1	BLACK								
2	FRAME	STEEL STRIP	1	Ni PLATED								
1	KNOB	POM	1	BLACK								